

For the finest sound . . .

Acrosound ★

Ultra-Linear

**OUTPUT
TRANSFORMERS**

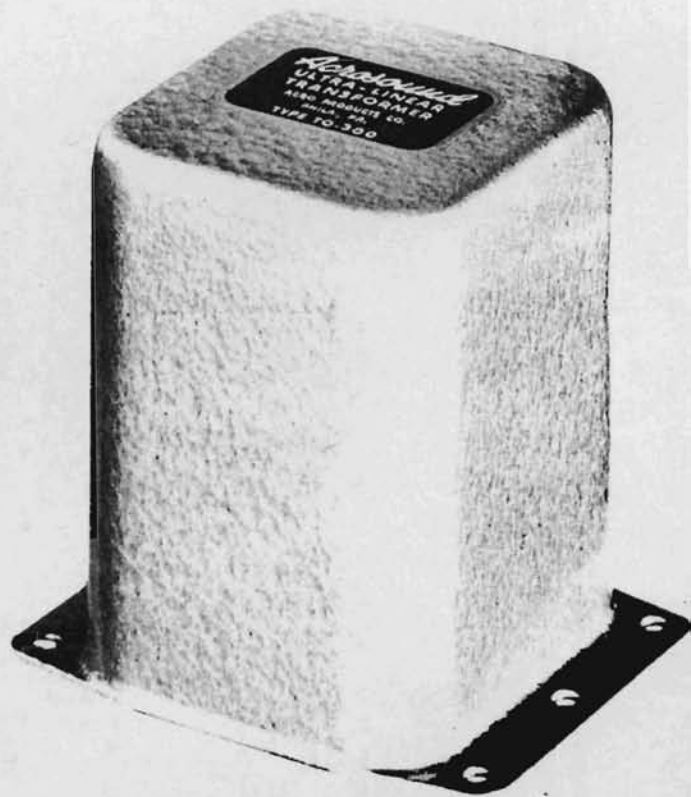
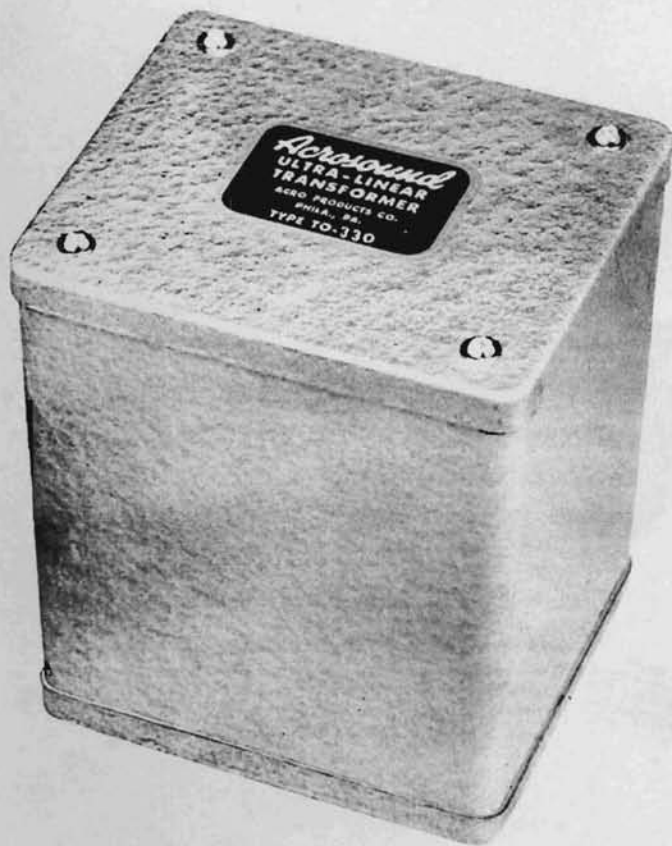

Acro Products Company, 369 Shurs Lane, Phila. 28, Pa

ACRO PRODUCTS COMPANY

Listed in this pamphlet are those items which Acro Products Company manufactures for industrial use and for distribution through electronic parts distributors. These stock components are designed for audio and instrumentation applications of the highest quality.

In addition, the facilities of Acro Products Company are available for specialty design and manufacture of transformers (audio, pulse, and power), reactors, and associated items of a great variety of types. Inquiries are invited for quotations on special units which are not readily available elsewhere.

Acro has the design capabilities and the production abilities and facilities for units of hard-to-obtain characteristics. If the design requirement calls for extra small size, unusually wide bandwidth, very low distortion, or other unique feature, Acro is prepared to tackle it.

Both multiple and single winding facilities are available; and production skill permits meeting of close tolerances and maintenance of specifications for both samples and production runs.

ACROSOUND ULTRA-LINEAR TRANSFORMERS

Transformer design has been called an art rather than a science. This indicates that two designers striving for a given level of performance will probably attempt to achieve it in two different ways. Likewise, they will set two different ceilings to their achievable levels of quality. Acrosound Ultra-Linear transformers have been designed for a level of performance which most designers believed unattainable at a competitive price. The methods by which the designs have been achieved are unique and are protected by United States patents, with foreign patents pending. Acrosound transformers are *better* transformers, and there are good reasons for this superiority.

- **Acrosound Design**—Acro design has distinctive features. It permits comparable performance on all taps of a tapped transformer. It is designed for wider bandwidth—far in excess of the audio band so as to allow more stable feedback and to insure good transient response. Acro transformers are designed for lowest possible distortion at *all* frequencies and *all* power levels using generous design margins which make all the performance ratings conservative.
- **Acrosound Materials**—Acro uses the finest grades of core material in specially shaped laminations. These are not the ordinary scrapless type of laminations as used in power transformers but a more expensive style which has unusually fine properties in audio design. Even such a comparatively small detail as potting compound has been integrated in the Acrosound design—a special microcrystalline wax is used for better protection and performance even though its cost is higher than conventional potting materials. All the materials have been selected for their opti-

imum contribution to performance rather than for purpose of cutting cost.

- **Acrosound Production**—Acro production of output transformers is carried out on winding equipment which has been specially designed and custom manufactured for producing this basic type of transformer. Windings are carried to the exact turn without deviation. Complete uniformity is achieved through maintenance of extremely close production tolerances.
- **Acrosound Testing**—*Every* Acrosound output transformer is subjected to a series of tests. These include: testing for balance on all balanced windings (ac balance is guaranteed to 1%); test for accuracy of reflected impedance between primary and all secondary windings and taps; test for shorted turns; test for shorts from primary to secondary, from primary to case, and from secondary to case; test for open windings; test of exciting current to insure maintenance of inductance and core power handling capacity; 2000 volt test of insulation. Additional extensive tests are applied to a representative sampling of production to insure maintenance of all performance characteristics.

Those are the reasons why Acrosound consistently gives the finest performance and why Acrosound output transformers have achieved the finest of reputations in the period since the beginning of 1950 when they were first introduced. A continuing program of research and development has produced new and better models; and without fanfare, new methods and techniques have been incorporated into Acro design and production which make Acrosound output transformers better than ever.

ACROSOUND ULTRA-LINEAR CIRCUITS

Top quality transformers make any circuit better. However, the best results come from the use of the finest quality in all parts of the system, and it is desirable to use quality circuits and quality transformers together. Therefore, in order to get optimum benefit from Acrosound output transformers, Acro Products Company has maintained a policy of continued research and development in the audio field so as to integrate transformers and circuits into better quality amplifiers.

One of the fruits of the program was development of the Ultra-Linear output stage which constitutes a basic advance in the audio art. This circuit has been widely described in the literature, extensively imitated, and is now universally accepted as the tops in high fidelity reproduction.

Briefly, the Ultra-Linear principle involves the mixing of plate and screen currents in the output transformer so that the dynamic plate characteristics of a tetrode are made more linear without decreasing its power sensitivity. This brings together the basic advantages of both triode tube type and tetrode tube type and makes an output stage which can be demonstrated to have less distortion than either triode or tetrode. The conventional arrangement uses carefully positioned taps on the primary winding to energize the screens; or if different dc potentials are required on plate and screen, the screens are energized through a tightly coupled tertiary winding.

This circuit permits lower distortion and better transient performance of the amplifier. To augment this, a special series of efficient, wide band, low distortion transformers were developed for use in Ultra-Linear circuits. This combination of circuit and transformer, tailored for each other, has resulted in a new standard of high fidelity performance. The combination has reached world wide fame because it makes for better amplifiers both on the basis of measurements and on the basis of listening comparisons.

The research policies which evolved the Ultra-Linear power output stage and Ultra-Linear transformers continue. New tube types and circuit variants have been uncovered which continue to bring improvement, and these are continually brought to the public via articles and media such as this pamphlet. Therefore, a large section of this pamphlet is devoted to circuitry, both Ultra-Linear and conventional, which will be of interest to all of those who seek better audio.

Many circuit types are illustrated in the schematics included in this pamphlet. These range in power output

from 10 watts to 100 watts. All of them are integrated designs in which factors of performance, stability, reliability, and efficiency have been balanced to provide outstanding quality.

In some cases deviations have been made from previously published versions of these circuits (both in trade journals and in earlier editions of this Acrosound pamphlet). These changes have been based on continued investigation of the circuits and contribute minor improvements where these have proven possible. The experience of users of these Acrosound circuits has been helpful in the development of circuit changes which lead to improved performance. The comments and questions of others who use these circuits are welcomed; and it is hoped that they can lead to further beneficial refinements for future release.

All of the designs shown provide audio quality of the very highest level and set performance standards for the entire high fidelity industry. They do not contain "gimmicks" or super-sensitive adjustments which make it unlikely that the builder be able to duplicate the performance of the original. Actually, the performance of any of these circuits can be readily replicated or surpassed by the audio experimenter using standard parts and conventional construction practices.

All of these designs have certain performance features in common. For example, the bandwidth of all of these amplifiers is far in excess of the customary audio spectrum in order to provide superior transient response. A minimum frequency response of plus or minus 1 db from 10 cps to 100 kc is available from any of the amplifiers; and several of the Ultra-Linear circuits extend this specification from 2 cps to 200 kc.

Rated output of these amplifiers is reached at very low distortion levels—the limit in this direction being set by the particular tubes used and by the balance of signals through push pull portions of the circuit. For example, the published IM curves on the Ultra-Linear Williamson circuit (page 8) showed 1% distortion at 20 watts output. However, with a matched set of output tubes and balanced drive to the output stage, 30 watts can be reached for the same distortion figure.

Distortion is also exceptionally low over a very wide frequency band. The rated power of these circuits is available from 20 cps to 20 kc with a minimum of distortion. This is rarely true of commercial amplifiers which have flat frequency response but in which distortion rises at frequency extremes.

The most important characteristic of an audio amplifier is its listening quality. The integration of top grade

output transformers and top grade circuitry leads to smooth, clean, natural sound. The circuits which follow have that natural listening quality in which various orchestral choirs are well defined, individual instruments are not muddled into the background, and there is no harshness or strain in the upper frequency regions.

Triode Circuit with Acrosound TO-250 Transformer (page 7)

The 2A3 type of triode has been a favorite of high fidelity constructors for many years. Many amplifiers using this tube or its modern equivalent, the 6B4, are still in existence and can be improved substantially through use of the TO-250 transformer and up-to-date circuitry. The circuit shown provides 10 watts of quality output with wider bandwidth and lower distortion than had ever been available from the older type circuits and components.

6L6 Circuit with TO-280 Transformer (page 7)

The beam tetrode, as exemplified by the 6L6 (or 5881) type of tube can be used as the basis of an efficient high quality amplifier using comparatively few stages and simple circuitry. The circuit shown uses a unique arrangement for obtaining a low impedance power source for the screen grids. This expedient, along with a quality output transformer and stable feedback arrangement, permits 24 watts of clean output with excellent distortion and transient characteristics.

Williamson Type Circuits with TO-300 and TO-290 Transformers (page 8)

Williamson type amplifiers are no longer rare or novel, but their popularity remains undiminished because they offer excellent quality and were one of the first truly high fidelity circuits available to the home constructor. The triode Williamson with the Acrosound TO-290 transformer was described in Radio and Television News, December 1950 and has been a source of pleasure to many high fidelity fans and music lovers. It provides about 12 watts of clean output, wide frequency response, and a flat power curve.

The Ultra-Linear Williamson arrangement with the Acrosound TO-300 transformer doubles the power of the triode version for a given distortion and also provides better transient performance as evaluated by square waves. This circuit has been described in Audio Engineering, June 1952 and Radio and Television News, February 1953. Many thousands of these amplifiers have been constructed by experimenters, kit assemblers, and manufacturers. Satisfied users everywhere know

that its performance is unequalled within its power bracket.

6V6 and EL-84 Circuits with Acrosound TO-270 and TO-310 Transformers, (page 9)

The 6V6 tube has been very popular in commercial amplifiers of about 10 watt capability. Many of these amplifiers can be substantially improved by conversion to one of the circuits shown. The circuit with the TO-270 preserves conventional tetrode operation of the tubes. That with the TO-310 furnishes Ultra-Linear operation with about 10 watts of output at 1% intermodulation distortion. This arrangement is basically similar to many 6V6 circuits which are popular, and conversion of these to Ultra-Linear operation is relatively simple. An example of this conversion was described in Radio and Television news, June 1954.

6Y6 Circuits with Acrosound TO-320 (page 9)

The 6Y6 is not well known for audio use however, experimentation indicated that under Ultra-Linear operation this tube was capable of unusually fine reproduction for lower power applications. Better than 18 watts of power can be had before distortion becomes significant.

The TO-310 ideally matches the popular EL-84 tube and this combination will provide an excellent 18 watt amplifier.

In conjunction with the TP-520 which provides the necessary 275 volts at 160 ma. a modest but extremely clean low power amplifier is realized.

Push Pull Parallel Ultra-Linear Amplifier with TO-330 Transformer (page 10)

The push pull parallel circuit shown is the "big brother" of the Ultra-Linear Williamson circuit. It does better than twice the output for a given distortion and makes an amplifier with less than 1% intermodulation distortion at 60 watts of output, and 40 watts is available at .25% IM. 20 watts of output are handled effortlessly over the band from 10 cps to 100 kc. and the full 60 watts is available from 20 cps to 20 kc. High power capability plus a damping factor of 16 give clean unmuddled reproduction of the heaviest bass passages while a smooth crystal clear treble range balances the bass.

100 Watt Amplifier with the TO-350 Transformer (page 11)

High Fidelity power to fill a stadium is obtainable in the 100 watt circuit featuring the unique TO-350

transformer. This transformer provides Ultra-Linear connection via a tertiary winding to energize the screen grids of type 6L16 tubes (or other tubes in which a dc difference between plate and screen is essential). This amplifier supplies its rated power within 1 db from 20 cps to 20 kc and offers tremendous power and excellent quality simultaneously. Other circuit variants with the 6L16 are of course practical. It is recommended, however, that the use of a low impedance driving source, such as the cathode follower arrangement shown, be utilized if optimum results are desired.

KT88 Circuits with Acrosound TO-340 (page 12)

The "big brother" of the popular KT-66 was introduced to this country through an article which appeared in the August 1957 issue of Radio Electronics Magazine. With 520 volts on the plates of the KT88's, better than 50 watts of essentially undistorted power can be obtained in self bias operation.

The circuit features an effective internal stabilization network which precludes high frequency peaking in the 100 to 200 kc regions and provides a smooth high frequency roll-off. The popular 6550 tube may also be used in this circuit with no changes.

The KT-88 can also be used in the high power Ultra-Linear Williamson circuit using fixed bias and the TO-330 shown on Page 13.

High Power Ultra-Linear Williamson Type Amplifier with 6550 Tubes (page 13)

For many applications, power output in excess of 50 watts is very desirable. It is now practical to convert existing Williamson (and Ultra-Linear Williamson)

type amplifiers to high powered Ultra-Linear use with the new Tung Sol 6550 tubes and the Acrosound TO-330 output transformer. Although this transformer was originally designed for push pull parallel operation of KT-66's and similar tubes, its characteristics have been found well suited for use with one pair of 6550 tubes operated at the voltages which are available in Williamson circuits.

The schematic on page 13 includes the original power supply and voltage amplifier stages of the Williamson type circuit. The power output stage has been modified for Ultra-Linear operation of the 6550 tube with fixed bias. This bias supply is small enough to add under existing chassis layouts. The only other circuit changes required for converting an existing amplifier, in addition to change in the output transformer, are those which adjust for 20 decibels of stable feedback. The networks added to the amplifier insure a generous margin of stability at both high and low frequencies without restriction of bandwidth.

The frequency response of this amplifier is plus or minus 1 db from 2 cps to over 200 kc with no peaking or raggedness. Intermodulation distortion is less than 1% up to 50 watts of output, and this power is available practically undistorted at any frequency from 20 cps to 20 kc. Transient response, as evaluated by step inputs and square waves, is excellent.

For users of Williamson circuits who wish to increase their available power without degradation of listening quality, this circuit is extremely convenient. In addition, its stability, compactness, and efficiency make it desirable for original construction of amplifiers with a conservative 50 watt power rating.

Write for descriptive literature on
Ultra-Linear II Amplifier Kit

OTHER LITERATURE AVAILABLE
Theory and Operation of the Ultra-Linear Circuit, 25¢

TRIODE CIRCUIT WITH ACRO SOUND TO-250 TRANSFORMER

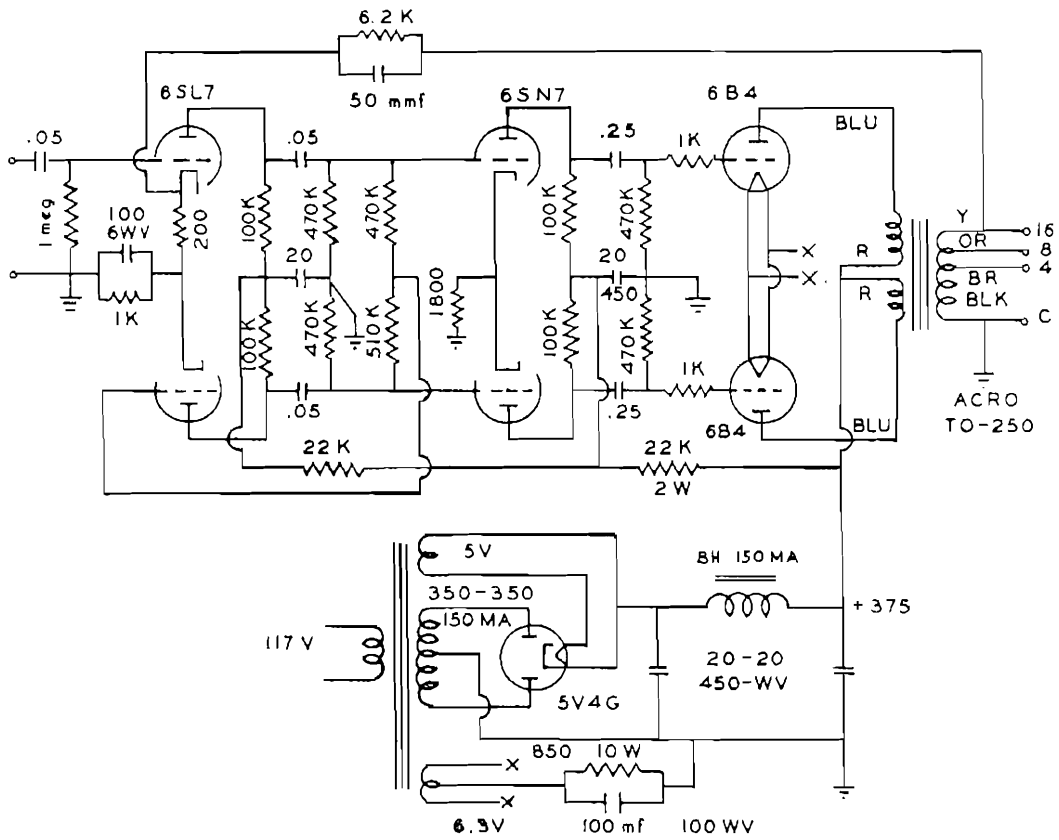

6L6 CIRCUIT WITH TO-280 TRANSFORMER

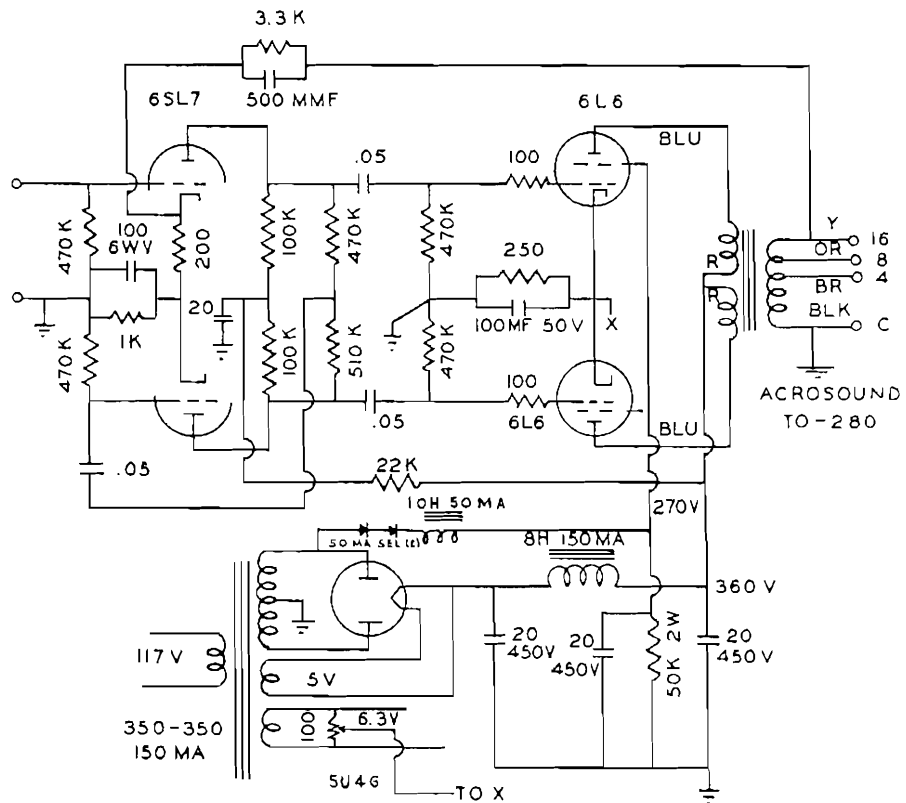

6V6 AND EL-84 CIRCUITS ULTRA-LINEAR WITH TO-310, TETRODE WITH TO-270

6Y6 CIRCUIT ULTRA-LINEAR WITH TO-320

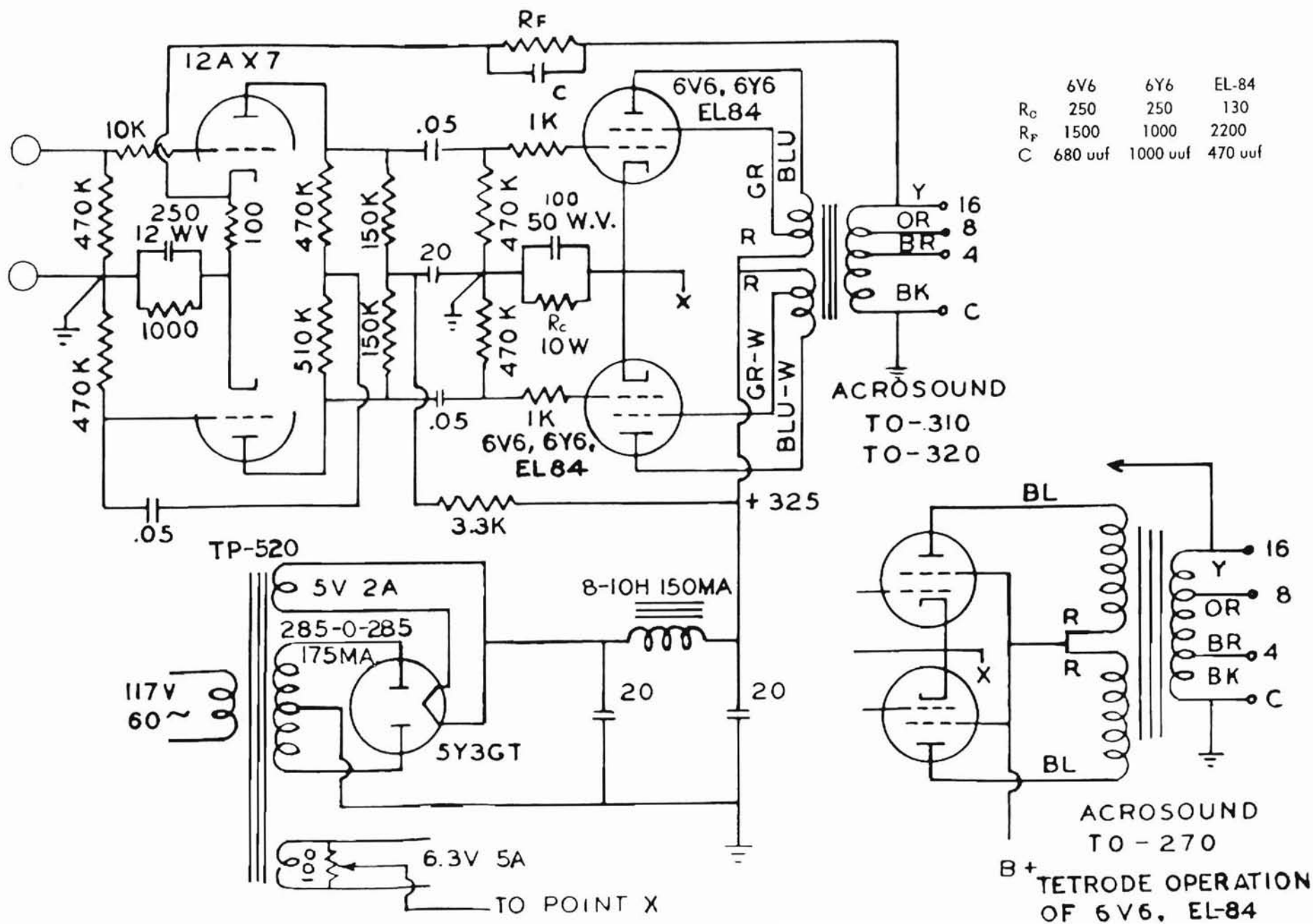

PUSH PULL PARALLEL ULTRA-LINEAR AMPLIFIER WITH TO-330 TRANSFORMER

01

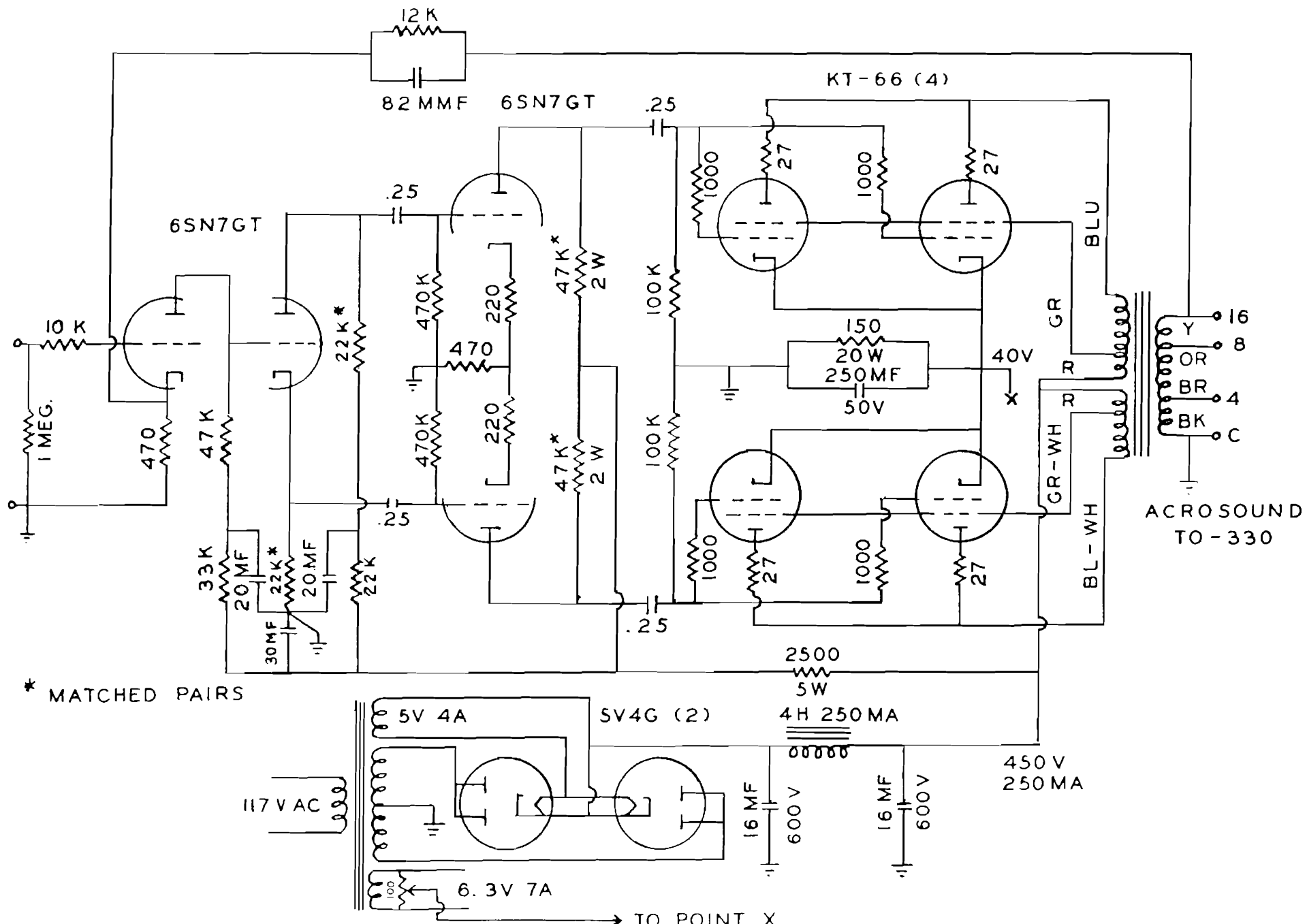

100 WATT AMPLIFIER WITH THE TO-350 TRANSFORMER

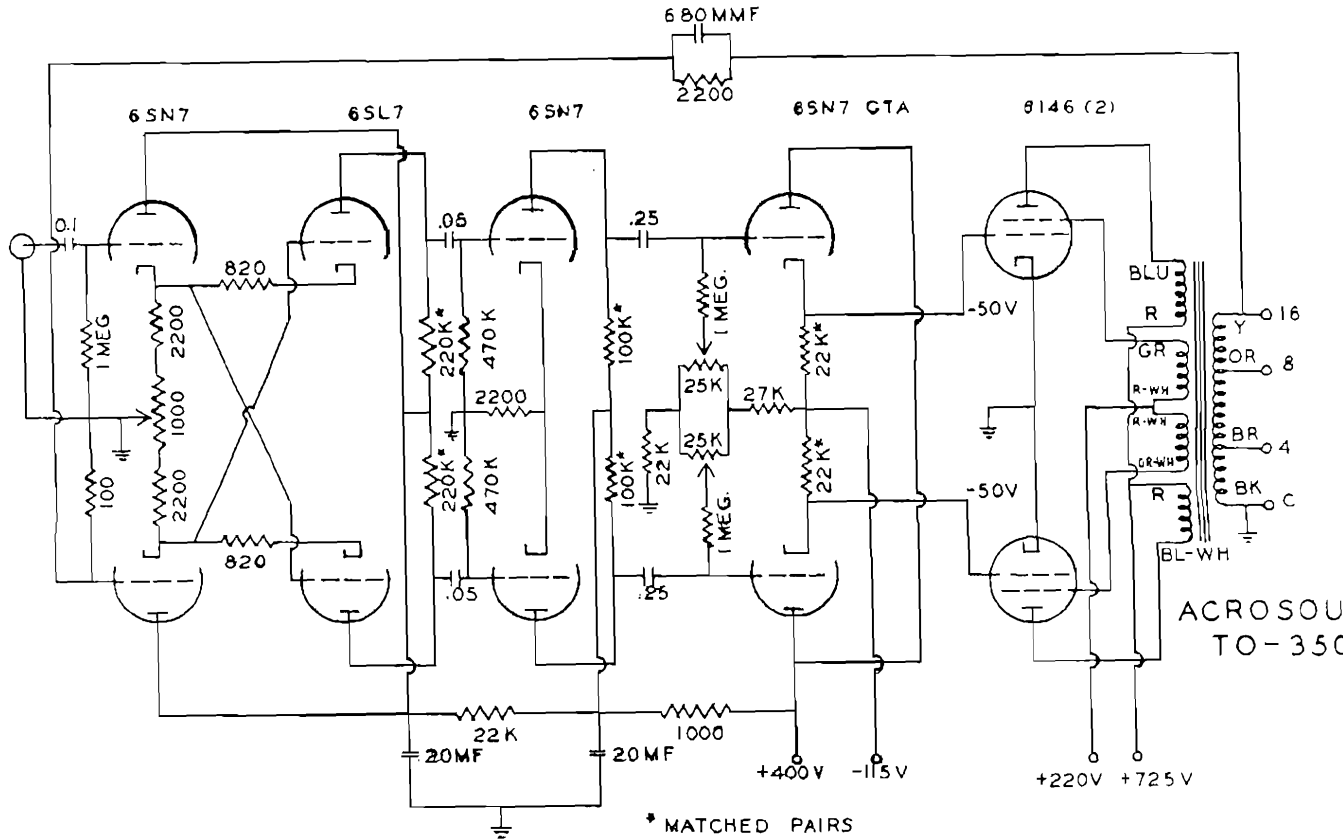

POWER SUPPLY FOR 100 WATT ULTRA-LINEAR AMPLIFIER

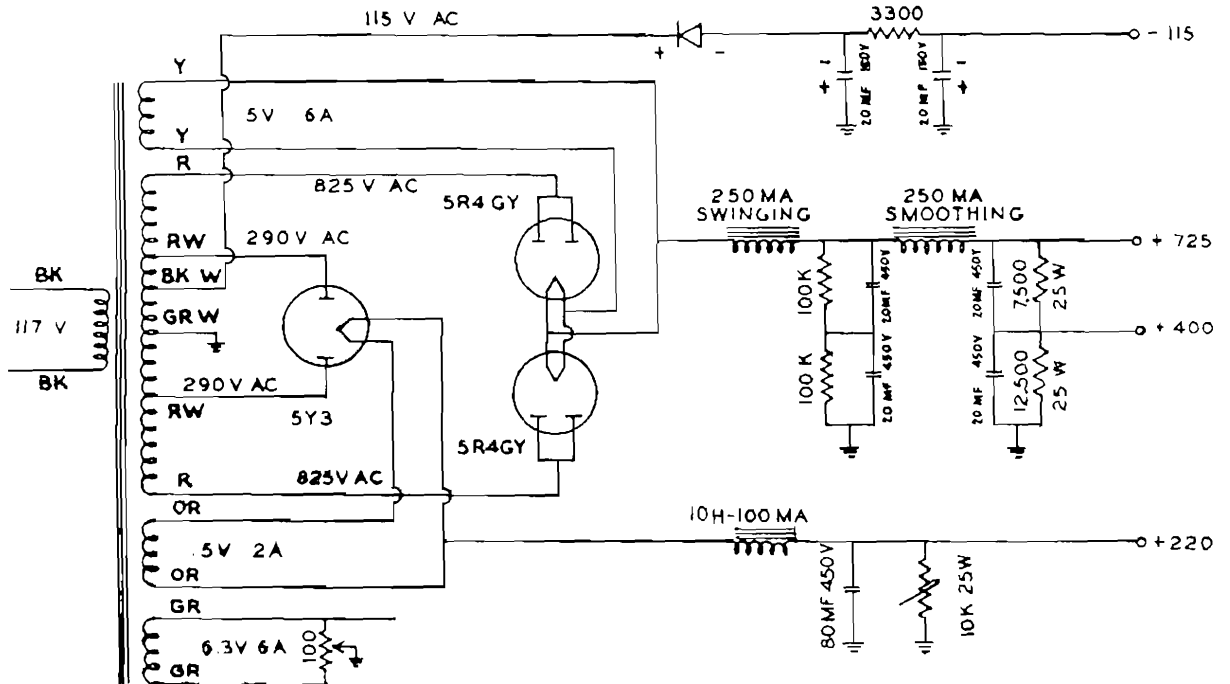

ACROSOUND
TP-550

ANY COMBINATION OF SEPARATE TRANSFORMERS WHICH WILL SUPPLY THE REQUISITE VOLTAGES CAN BE USED. THE IMPORTANT CONSIDERATION IN THIS SUPPLY IS THAT PLATE AND SCREEN SUPPLIES HAVE GOOD REGULATION.

KT88 AMPLIFIER USING THE TO-340 TRANSFORMER

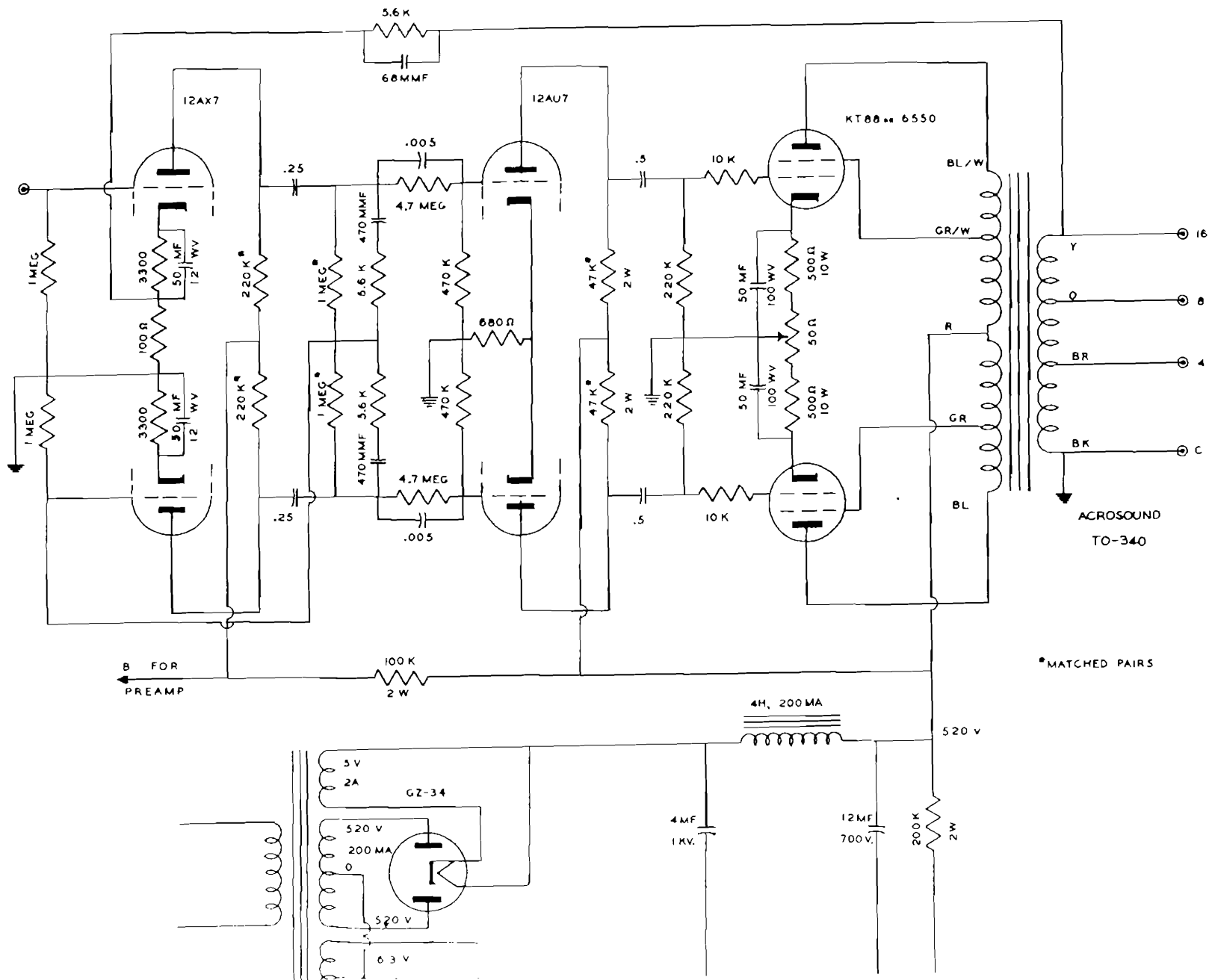

MOUNTING TEMPLATES

MODELS IN TYPE "A" CASE

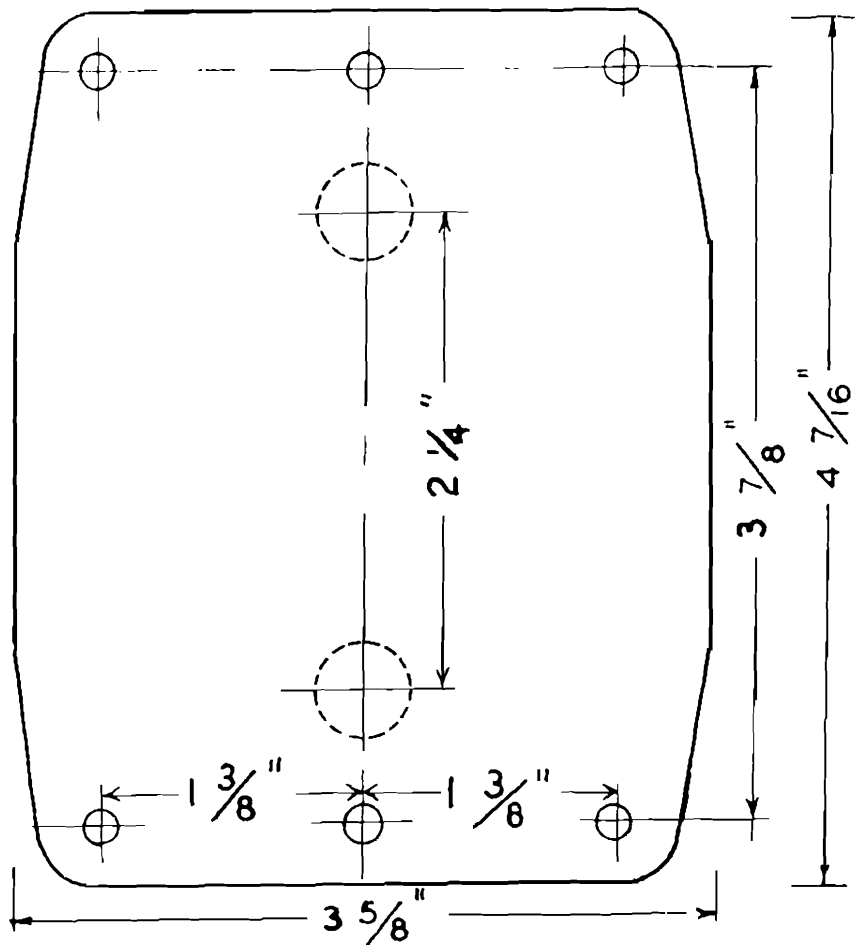

MODELS IN TYPE "B" CASE

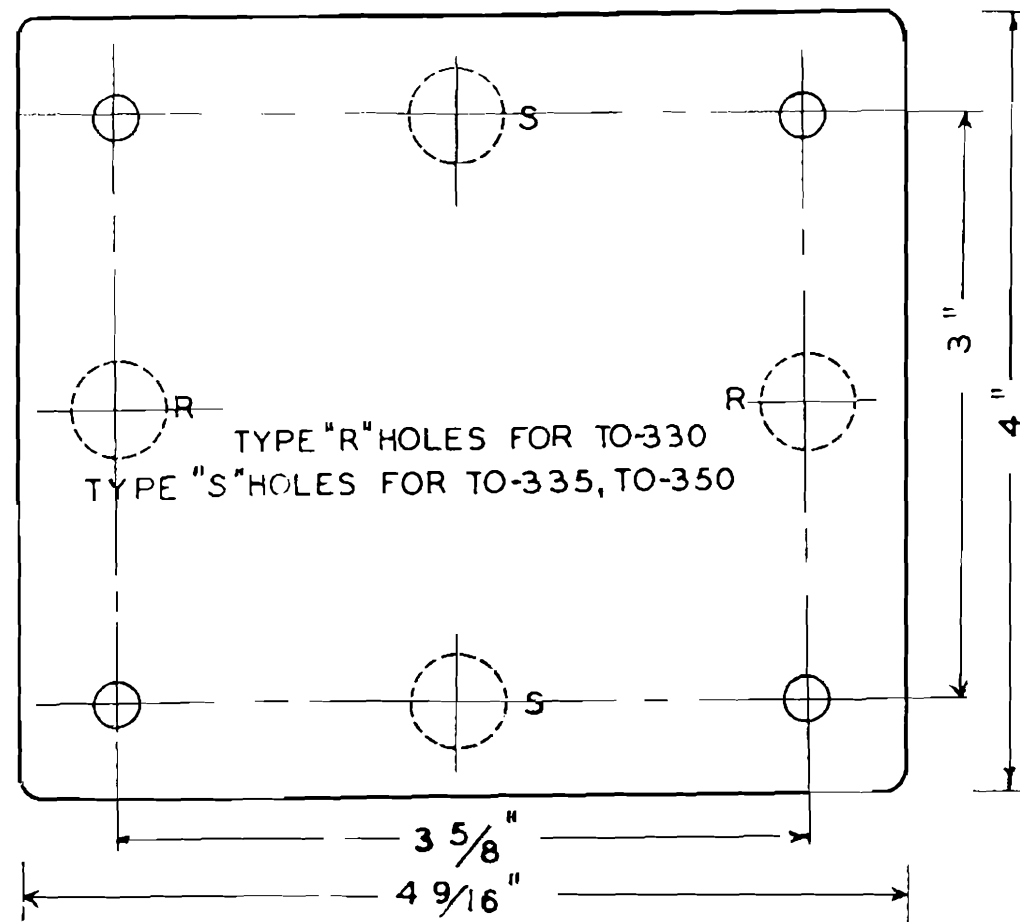

HOOKUP DIAGRAMS FOR OUTPUT TRANSFORMERS

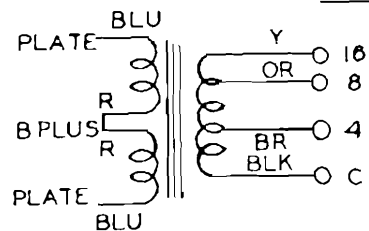

CONNECTIONS FOR
"200" SERIES

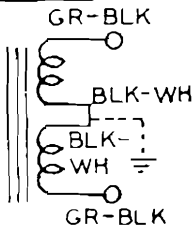

CONNECTIONS FOR 500 OHMS
(parallel the sections
for 125 OHM output)

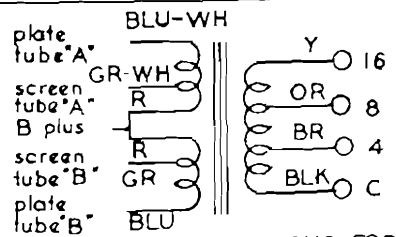

CONNECTIONS FOR
"300" SERIES

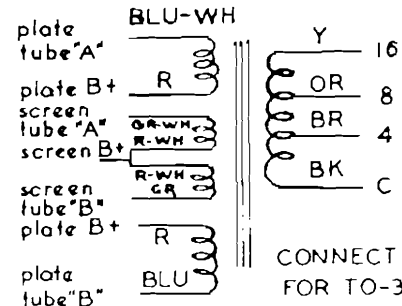

CONNECTIONS FOR TO-350

ACROSOND TRANSFORMERS

OUTPUT TRANSFORMERS

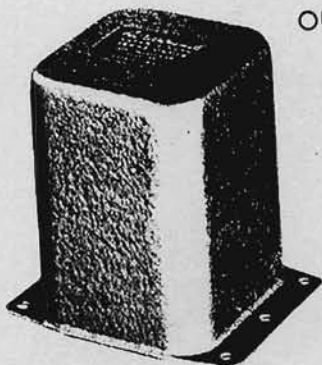

Case Type "A"
3 3/8 x 3 1/4 x 4 1/4 high



Case Type "B"
4 x 4 5/8 x 5 7/8 high

MODEL	IMPEDANCES*	POWER RATING	FREQUENCY RESPONSE	RATED PRIMARY CURRENT PER TUBE	PERMISSIBLE DC PRIMARY UNBALANCE	CASE TYPE	WEIGHT	NET PRICE	APPLICATION
T0-230	3000 plate-to-plate 4, 8, 16 secondary	20 watts— 20 cps to 20 kc 40 watts— 30 cps to 15 kc	±1 db 10 cps to 40 kc	150 ma	20%	A	7 lbs.	\$14.50	For use with 6B4's or 2A3's self bias pp par. 6L6's, etc.
T0-250	5000 plate-to-plate 4, 8, 16 secondary	10 watts— 20 cps to 20 kc 20 watts— 30 cps to 15 kc	±1 db 10 cps to 40 kc	75 ma	10%	A	6 lbs.	11.75	For use with 6B4's or 2A3's self bias. 6L6's, class A, etc.
T0-270	10,000 plate-to-plate 4, 8, 16 secondary	10 watts— 20 cps to 20 kc 20 watts— 30 cps to 15 kc	±1 db 10 cps to 40 kc	75 ma	10%	A	6 lbs.	11.75	For use with 6V6's, 6K6's, etc.
T0-280	9000 plate-to-plate 4, 8, 16 secondary	20 watts— 20 cps to 20 kc 40 watts— 30 cps to 15 kc	±1 db 10 cps to 40 kc	75 ma	10%	A	7 lbs.	14.50	For use with 6L6's, class AB1
T0-290	12,000 plate-to-plate 4, 8, 16 secondary	20 watts— 20 cps to 20 kc 40 watts— 30 cps to 15 kc	±1 db 10 cps to 40 kc	75 ma	10%	A	7 lbs.	15.75	For use with triode connected 807's or 5881's in Williamson type circuit
T0-300	6600 plate-to-plate 4, 8, 16 secondary	20 watts— 20 cps to 30 kc 40 watts— 30 cps to 20 kc	±1 db 10 cps to 100 kc	75 ma	15%	A	7 lbs.	24.75	For Ultra-Linear operation of KT-66's, 807's, 5881's, 1614's and 6L6's, Ultra-Linear conversion of Williamson type circuits
T0-310	8000 plate-to-plate 4, 8, 16 secondary	10 watts— 20 cps to 30 kc 20 watts— 30 cps to 20 kc	±1 db 10 cps to 100 kc	75 ma	10%	A	6 lbs.	18.75	For Ultra-Linear operation of 6V6's or EL-84's
T0-320	3500 plate-to-plate 4, 8, 16 secondary	10 watts— 20 cps to 30 kc 20 watts— 30 cps to 20 kc	±1 db 10 cps to 100 kc	75 ma	10%	A	6 lbs.	18.75	For Ultra-Linear operation of 6Y6's
T0-330	3800 plate-to-plate 4, 8, 16 secondary	50 watts— 20 cps to 30 kc 100 watts— 30 cps to 20 kc	±1 db 10 cps to 100 kc	150 ma	15%	B	14 lbs.	39.75	For push pull Ultra-Linear 6550's, EL-34's, KT88's, 6CA7's or for push pull parallel operation of KT-66's, 807's, etc.
T0-340	5000 plate-to-plate 4, 8, 16 secondary	50 watts— 20 cps to 30 kc 100 watts— 30 cps to 20 kc	±1 db 10 cps to 100 kc	150 ma	15%	B	14 lbs.	39.75	For push pull Ultra-Linear 6550's KT-88's, in self bias operation
T0-350	6600 plate-to-plate 4, 8, 16 secondary	100 watts— 20 cps to 20 kc	±1 db 7 cps to 70 kc	175 ma	10%	B	14 lbs.	49.50	For Ultra-Linear operation of 6146 tubes using tertiary winding for screen connection.

* All models available with additional line winding (125 and 500 ohms) at extra cost of \$8.00 net for models with numbers up to T0-320 and \$10.00 net for models T0-330 and T0-350. Models with line winding are designated by model numbers ending in "5." For example, Model T0-300 with additional line winding is specified as T0-305.

** All cases are furnished in silver grey hammerlock finish. 10-inch color coded wire leads are brought out through case bottoms. Case type "A" mounts with base flange. Case type "B" is provided with four #8 mounting lugs.

POWER TRANSFORMERS				Net Price
Model	Voltages		Use	
TP-520	250-0-250	175 ma	For 6Y6, 6V6, EL84	
	6.3V	5a	Amplifiers	9.75
	5V	2a		
TP-550	825-290-0-100-290-825			
	6.3V	6a	For 6146	
	5V	6a	Amplifiers	33.75
	5V	2a		

All power transformers supplied in gray hammertone end bells with upright mounting.

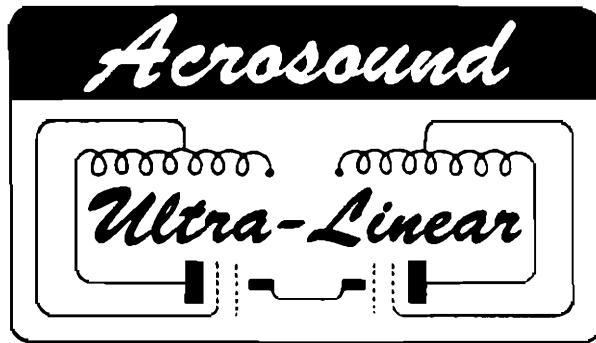

AUTHENTIC ACROSOUND ULTRA-LINEAR
TRANSFORMERS AND CIRCUITS ARE
YOUR GUARANTEE OF QUALITY